

# MICHELIN® Truck Tire Reference Chart

January 2011



# MICHELIN® TRUCK TIRE REFERENCE CHART

## STEER / ALL-POSITION TIRES

**XZA3®**



- Exceptional fuel-efficient\* tire that helps deliver long original tread life
- Wider shoulder and footprint help deliver improved shoulder wear, handling and response
- Directional tread built for irregular wear resistance and longer tread life
- 7/7/3\*\* manufacturer's limited casing warranty

LH	R	O/O	U
275/80R22.5			Tread Depth
MICHELIN® XZA3®			19
Goodyear® G395® LHS® Fuel Max®			18
Bridgestone® R287			16

**XZA® (365/70R22.5)**



- Advanced Technology™ compounding offers excellent fuel economy\*
- Engineered for irregular wear resistance
- Over 7,000 trapezoidal micro sipes on groove edges help break water surface tension to promote traction on wet and slippery road surfaces
- Original shoulder groove design offers enhanced resistance to uneven shoulder wear

LH	R	O/O	U
365/70R22.5			Tread Depth
MICHELIN® XZA®			19
Goodyear®			N/A
Bridgestone®			N/A

**XZA3® Antisplash™**



- Unique Antisplash™ feature reduces splash trajectory height by more than 50%
- Ultra fuel-efficient\* tire that helps deliver long original tread life
- Directional tread
- 7/7/3\*\* manufacturer's limited casing warranty

LH	R	O/O	U
275/80R22.5			Tread Depth
MICHELIN® XZA®3 Antisplash			19
Goodyear®			N/A
Bridgestone®			N/A

**XZA2® Energy\*\*\***



- Optimized channel design allows for long tread life and minimized irregular wear
- Low rolling resistance compounds for fuel economy\* in highway service
- Optimized for steer axle service

LH	R	O/O	U
315/80R22.5			Tread Depth
MICHELIN® XZA®2 Energy			16
Goodyear® G291™			18
Bridgestone® R294			19

**XZA®-1+**



- Decoupling groove built for resistance to irregular wear
- Optimized for steer axle highway service
- Groove wall sipes help inhibit onset of irregular wear and improve wet traction

LH	R	O/O	U
11R22.5			Tread Depth
MICHELIN® XZA®-1+			18
Goodyear® G395® LHS®			18
Bridgestone® R280			18

**XZA®1\*\*\***



- Optimized for all-position heavy axle loads
- Variable groove angles help reduce irregular wear and improve overall performance

LH	R	O/O	U
315/80R22.5			Tread Depth
MICHELIN® XZA®1			18
Goodyear® G291™			18
Bridgestone® R294			19

**XZE®**



- Solid shoulders to help resist scrub
- Curb guards on sidewalls
- Deep, wide tread
- Full depth siping for efficient traction
- Compounds for scrub resistance
- Groove bottom protectors help defend against stone drilling

LH	R	O/O	U
245/70R19.5			Tread Depth
MICHELIN® XZE®			18
Goodyear® G149 RSA®			16
Bridgestone® R250F			19

**XZE2™**



- Enhanced application specific compound to promote resistance to aggression and longer tread life
- **Matrix™** Siping technology and micro sipes protect against irregular wear
- Zig-zag grooves and sipes help increase traction in new and worn tire conditions
- North American design

LH	R	O/O	U
11R22.5			Tread Depth
MICHELIN® XZE2™			22
Goodyear® G661™ HSA™			22
Bridgestone® R260F			22

**XZE® 2/XZE® 2+**



- Buttressed shoulder helps resist wear in high scrub applications
- Full-depth sipes offer exceptional traction throughout the usable life of the tire
- European design

LH	R	O/O	U
295/80R22.5			Tread Depth
MICHELIN® XZE®2+			20
Goodyear® MARATHON® LHS™			18
Bridgestone® R250F			19

\* Fuel savings are estimates based on comparative rolling resistance. Actual on-road savings may vary.

\*\* 7/7/3 Manufacturer's Limited Casing Warranty: 700,000 miles, 7 years, or 3 retreads for MICHELIN® XZA3®, XZA3® Antisplash™, XZA2®, and XZA2® Energy tires only. See limited warranty for details.

\*\*\* "No bus shall be operated with regrooved, recapped or retreaded tires on the front wheels." US Code of Federal Regulations: Title 49, Transportation; Part 393.75. Exceeding the legal speed limit is neither recommended nor endorsed.

LH – Long Haul, R – Regional, O/O – On/Off Road, U – Urban

# MICHELIN® TRUCK TIRE REFERENCE CHART

## STEER / ALL-POSITION TIRES

**XRV®**



- Exclusively for motorhome use
- Cool running tread design
- Excellent ozone resistance sidewalls
- Stable tread with cool running compound engineered to reduce squirm and lower heat for improved handling and durability

LH	R	O/O	U
235/80R22.5			Tread Depth
MICHELIN® XRV®			16
Goodyear® G670 RV® (245/75)			15
Bridgestone® R250F			19

**XZA®**



- Excellent steer tire for regional operation
- Designed for long mileage and even tread wear
- Zig-zag design for true all-position use

LH	R	O/O	U
8R19.5			Tread Depth
MICHELIN® XZA®			16
Goodyear® G171™ LT			18
Bridgestone®			N/A

**X One® XZY®3**



- Long treadlife and outstanding chip and cut resistance in on/off road service
- Flat, stable contact area for long, even wear provided by Infini-Coil Technology™
- Enhanced protection against stone drilling from variable pitch groove walls and groove bottom protectors in center grooves

LH	R	O/O	U
455/55R22.5			Tread Depth
MICHELIN® X One® XZY®3			23
Goodyear®			N/A
Bridgestone®			N/A

**XZY®3**



- Tread compound offers excellent protection against aggression, chipping and scaling
- Extra robust casing construction for excellent retreadability
- Maximized soft soil and mud traction throughout the tire life

LH	R	O/O	U
11R22.5			Tread Depth
MICHELIN® XZY®3			24
Goodyear® G288 MSA®			25
Bridgestone® M850			24

**XZY®3 WIDE BASE**



- Casing durability and protection from increased shoulder and sidewall thickness
- Improved traction and floatation in soft soil and mud
- Great resistance to shocks, bruising and penetrations

LH	R	O/O	U
425/65R22.5			Tread Depth
MICHELIN® XZY®3 WIDE BASE			23
Goodyear® G286A™ S5			20
Bridgestone® M844F			24

**X One® XZU®S**



- Optimized for weight savings in urban and regional operation
- Enhanced protection against stone drilling from variable pitch groove walls and groove bottom protectors in all grooves
- Reinforced bead package for resistance to heat
- 23/32nds original tread depth
- Infini-Coil Technology™

LH	R	O/O	U
455/55R22.5			Tread Depth
MICHELIN® X One® XZU®S			23
Goodyear®			N/A
Bridgestone®			N/A

**XZU®S2**



- Up to 20% increase in removal mileage<sup>(1)</sup> due to new 4-rib tread design
- Improved retreadability<sup>(1)</sup> due to a more robust tread design
- Increased resistance<sup>(1)</sup> to high brake temperatures common in urban stop/start service due to updated bead design

(1) When compared to the MICHELIN® XZU®S tire.

LH	R	O/O	U
315/80R22.5			Tread Depth
MICHELIN® XZU®S2			23
Goodyear® G289™ WHA™			24
Bridgestone® M860			24

**XZU®S**



- 10,000 lb/tire capacity at 65 mph\*
- Helps improve bead durability from extra long metallic chafer
- Long tread life in high scrub urban applications, such as waste vehicles
- Resists high brake temperatures and high crown operating temperatures

LH	R	O/O	U
315/80R22.5			Tread Depth
MICHELIN® XZU®S			23
Goodyear® G289™ WHA™			24
Bridgestone® M860			24

**XZU®S WIDE BASE**



- Significant increase in tread life with new tread compounds and increased tread volume
- 65 mph\* rating with optimized scrub resistance and reduced operating temperatures in the crown area
- Fosters reduced mounting and dismounting damages with Michelin's rounded bead toe design

LH	R	O/O	U
425/65R22.5			Tread Depth
MICHELIN® XZU®S WIDE BASE			23
Goodyear® G286A™ S5			20
Bridgestone® M844F			24

\* Exceeding the legal speed limit is neither recommended nor endorsed.  
LH – Long Haul, R – Regional, O/O – On/Off Road, U – Urban

# MICHELIN® TRUCK TIRE REFERENCE CHART

## STEER / ALL-POSITION TIRES

### XZU®3\*



- Optimized for urban operation with frequent starts and stops
- Extended retreadability with extra robust casing and bead design
- *Matrix*™ sipes help provide excellent traction and even wear throughout life of tire
- Helps improve bead durability from extra long metallic chafer

LH	R	O/O	U
305/85R22.5			Tread Depth
MICHELIN® XZU®3			26
Goodyear® G291™ (315/80)			18
Bridgestone® R260 F			22

### XZU®2\*



- Built-up sidewall protectors provide protection against most curb damage
- Sidewall wear indicators promote timely tire rotation for long casing life and enhanced retreadability
- Wide, deep circumferential grooves and full-depth sipes help promote excellent traction throughout the life of the tire

LH	R	O/O	U
305/70R22.5			Tread Depth
MICHELIN® XZU®2			22
Goodyear® G291™ (315/80)			18
Bridgestone® R260 F			22

### X COACH XZ\*



- Charter bus tire designed for mileage safety and comfort
- New tread design helps deliver up to 15% higher mileage, while maintaining superior performance<sup>(1)</sup>
- Central zig-zag tread grooves help deliver improved grip for a shorter braking distance on wet or icy roads<sup>(1)</sup>

(1) When compared to the MICHELIN® XZA2® Energy tire.

LH	R	O/O	U
295/80R22.5			Tread Depth
MICHELIN® X® Coach XZ			19
Goodyear® G662 RSA® FuelMax®			22
Bridgestone® R250 F			19

### XFE WIDE BASE STEER



- Dual compound tread rubber helps ensure cool operating temperatures and helps keep tire wear rate low
- Deep, wide channels help provide excellent water evacuation throughout the life of the tire
- Lateral siping enhance traction and braking

LH	R	O/O	U
385/65R22.5			Tread Depth
MICHELIN® XFE™ WIDE BASE STEER			21
Goodyear® G286A™ SS			19
Bridgestone® M844F			23

\* "No bus shall be operated with regrooved, recapped or retreaded tires on the front wheels." US Code of Federal Regulations: Title 49, Transportation; Part 393.75. Exceeding the legal speed limit is neither recommended nor endorsed.  
LH – Long Haul, R – Regional, O/O – On/Off Road, U – Urban

# MICHELIN® TRUCK TIRE REFERENCE CHART

## DRIVE TIRES

### X One® XDA® Energy



- The most fuel efficient\* drive tire available for North American long haul trucks
- **Matrix™** Siping technology helps provide exceptional traction on dry and slippery surfaces. The 3D **Matrix™** sipes lock together for the stability normally associated with solid tread blocks
- Engineered to replace duals
- Directional tread design

LH	R	O/O	U
445/50R22.5 Tread Depth			
MICHELIN® X One® XDA® Energy			24
Goodyear® G392 SSD®			26
Bridgestone® Greatec® Drive			26

### X One® XDN®2



- Multiple tread compounds to keep the casing cooler and optimize retreadability
- Infini-Coil Technology™ incorporates 1/4 mile of steel cable
- Extra wide tread width for excellent stability and long wearlife
- Weight savings of approximately 371 lbs per tractor, when compared to the MICHELIN® XDN®2 tire

LH	R	O/O	U
445/50R22.5 Tread Depth			
MICHELIN® X One® XDN®2			27
Goodyear® G392 SSD®			26
Bridgestone® Greatec® Drive			26

### XDA®5



- Regenerating tread features from MICHELIN® Durable Technologies for excellent traction throughout the life of the tire
- **Matrix™** Siping technology helps provide exceptional traction on dry and slippery surfaces
- Extra-wide tread width and solid shoulders give excellent stability, handling, and long wear life

LH	R	O/O	U
11R22.5 Tread Depth			
MICHELIN® XDA®5			30
Goodyear® G372 LHD®			30
Bridgestone® M726 EL			32

### XDA3®/XD2®



- Ultra-fuel efficient\* drive-axle tire designed for long wear and quiet ride
- 7/7/3\*\* manufacturer's limited casing warranty
- Efficient stone rejection from variable groove wall angles
- 26/32nds original tread depth

LH	R	O/O	U
275/80R22.5 Tread Depth			
MICHELIN® XDA3®			26
Goodyear® G305® LHD™ FuelMax®			26
Bridgestone® M720			26

### XDA® Energy



- Advanced Technology™ tread compounds for outstanding fuel efficiency\*
- Alternating groove wall angles help resist stone retention and promote improved traction throughout the life of the tire
- 7/7/3\*\* manufacturer's limited casing warranty

LH	R	O/O	U
275/80R22.5 Tread Depth			
MICHELIN® XDA® Energy			26
Goodyear® G305® LHD™ FuelMax®			26
Bridgestone® M720			26

### XDN®2/XDN®2 Grip



- All-weather highway drive tire
- **Matrix™** sipes help deliver exceptional traction and excellent wear
- 27/32nds original tread depth
- MICHELIN® XDN®2 Grip is directional tread
- Wide open shoulder grooves deliver additional traction balanced with tread life

LH	R	O/O	U
11R22.5 Tread Depth			
MICHELIN® XDN®2			27
Goodyear® G372A LHD®			30
Bridgestone® M726 EL			32

### X MultiWay XD



- Excellent durability and a new tread pattern that reduces stone retention
  - Improved grip on wet and slippery roads due to double wave and raindrop sipe technologies.
  - Increased mileage<sup>(1)</sup> from a deeper, wider tread with MICHELIN® Durable Technologies.
- (1) When compared to the MICHELIN® XDE®2+ tire.

LH	R	O/O	U
11R22.5 Tread Depth			
MICHELIN® X MULTIWAY XD			23
Goodyear®			N/A
Bridgestone®			N/A

### XDE® M/S



- All-purpose drive tire for regional/P&D applications
- Open shoulder design offers excellent traction, especially in loose soil and mud
- Ⓢ Versions feature chip/cut resistant compound

LH	R	O/O	U
11R22.5 Tread Depth			
MICHELIN® XDE® M/S			26
Goodyear® G328™			28
Bridgestone® M711			26

### XDE®2+



- Tread block design featuring five longitudinal sipes for optimized grip and traction
- New damage resistant rubber compound for improved removal mileage
- Tread designed to minimize irregular wear
- Directional tread pattern to minimize stone retention

LH	R	O/O	U
11R22.5 Tread Depth			
MICHELIN® XDE®2+			25
Goodyear® G338 1AD®			30
Bridgestone® M725			30

\* Fuel savings are estimates based on comparative rolling resistance. Actual on-road savings may vary.

\*\* 7/7/3 Manufacturer's Limited Casing Warranty: 700,000 miles, 7 years, or 3 retreads for MICHELIN® XZA3®, XZA3® Antisplash™, XDA3®, and XDA® Energy tires only. See limited warranty for details.

Exceeding the legal speed limit is neither recommended nor endorsed.

LH – Long Haul, R – Regional, O/O – On/Off Road, U – Urban

# MICHELIN® TRUCK TIRE REFERENCE CHART

## DRIVE TIRES

### X Works XDY®



- Improved durability<sup>(1)</sup> due to a more robust center region of the tread
  - 10% improved removal mileage<sup>(1)</sup> due to the wider tread width
  - More efficient mud evacuation<sup>(1)</sup> due to directional tread
  - Excellent protection from shocks, snags and impacts due to extra-thick sidewall
- (1) When compared to the MICHELIN® XDY®3 tire.

LH	R	O/O	U
<b>11R22.5</b> Tread Depth			
MICHELIN® X Works XDY®			30
Goodyear® G282 MSD™			28
Bridgestone® L320			31

### XDY®3



- Tread compound offers excellent protection against aggression, chipping and scaling in mixed service
- Groove bottom protectors help guard against stone penetrations
- Massive open shoulder design helps provide maximized traction
- 31/32nds original tread depth

LH	R	O/O	U
<b>11R22.5</b> Tread Depth			
MICHELIN® XDY®3			31
Goodyear® G282 MSD™			28
Bridgestone® L320			31

### XDY-2™



- Deep directional tread optimized for traction and mileage in severe, on/off road service
- Chip and cut resistant compound
- Excellent casing protection
- Sidewall protection to help minimize damage

LH	R	O/O	U
<b>11R22.5</b> Tread Depth			
MICHELIN® XDY-2™			30
Goodyear® G282 MSD™			28
Bridgestone® L320			31

### XDY-EX2™



- Improved off-road and mud traction due to a more aggressive tread redesign with more void area
- Excellent crown durability and retreadability due to significantly reduced stone retention
- Excellent protection from shocks, snags and impacts due to extra-thick sidewall

LH	R	O/O	U
<b>11R24.5</b> Tread Depth			
MICHELIN® XDY-EX2™			32
Goodyear® G177™			32
Bridgestone® M775			33

### XDY-EX™



- Extra aggressive design for vehicles operating in extreme conditions
- Shock pads at all belt edges offer additional long-term casing life
- Special compound to help resist chipping and scaling
- Extra deep 32/32nds original tread depth

LH	R	O/O	U
<b>11R24.5</b> Tread Depth			
MICHELIN® XDY-EX™			32
Goodyear® G177™			32
Bridgestone® M775			33

### XDS® / XDS®2 (Standard Sizes)



- Rugged directional tread design helps boost snow and ice traction
- 3D *Matrix*™ Siping helps provide exceptional traction on dry and slippery surfaces
- Over 450 full-depth, zig-zag sipes enhance block stability and provide extra bite, especially in deep snow

LH	R	O/O	U
<b>11R22.5</b> Tread Depth			
MICHELIN® XDS®2			26
Goodyear® G244 MSD®			28
Bridgestone® L320			31

### XDS®2 (19.5" Wheel)



- Outstanding traction on wet and slippery surfaces from over 700 3D *Matrix*™ sipes
- Optimized for stone rejection with variable angled groove walls and groove bottom protectors
- 19.5" sizes
- 18/32nds original tread depth
- Non-directional tread

LH	R	O/O	U
<b>225/70R19.5</b> Tread Depth			
MICHELIN® XDS®2			18
Goodyear® G622 RSD® (265/70)			21
Bridgestone® M724F			20

Exceeding the legal speed limit is neither recommended nor endorsed.  
LH – Long Haul, R – Regional, O/O – On/Off Road, U – Urban

# MICHELIN® TRUCK TIRE REFERENCE CHART

## TRAILER TIRES

**X One® XTA®**



- Ultra-fuel efficient\* with Infini-Coil Technology™
- Engineered to replace duals in fuel and weight sensitive long haul trailer applications
- 13/32nds original tread depth
- Four decoupling grooves to resist irregular wear

LH	R	O/O	U
445/50R22.5			Tread Depth
MICHELIN® X One® XTA®			13
Goodyear®			N/A
Bridgestone® Greatec® Trailer			14

**X One® XTE®**



- Trailer tire designed to replace duals in high scrub applications
- Helps deliver substantial weight savings versus comparable dual assembly
- Infini-Coil Technology™ belt promotes excellent vehicle stability
- Deep, 16/32nds original tread depth

LH	R	O/O	U
445/50R22.5			Tread Depth
MICHELIN® X One® XTE®			16
Goodyear®			N/A
Bridgestone® Greatec® Trailer			14

**XT-1®**



- Fuel efficient\* line haul trailer tires
- 12/32nds original tread depth
- Tread groove design helps against irregular wear and provides good wet weather performance

LH	R	O/O	U
275/80R22.5			Tread Depth
MICHELIN® XT-1®			12
Goodyear® G316 LHT™ FuelMax®			12
Bridgestone® R195F			11

**XTA®**



- Optimized for low bed trailer application
- 15" and 17.5" sizes

LH	R	O/O	U
215/75R17.5			Tread Depth
MICHELIN® XTA®			15
Goodyear® G114™ LHT™			16
Bridgestone® R184			15

**XTA® Energy**



- Ultra-fuel efficient\* long haul trailer tire
- Available in low profile 22.5"
- Designed for long, smooth wear
- 13/32nds original tread depth
- Four circumferential grooves for excellent wet weather performance

LH	R	O/O	U
275/80R22.5			Tread Depth
MICHELIN® XTA® Energy			13
Goodyear® G316 LHT™ FuelMax®			12
Bridgestone® R195F			11

**XTA®2 Energy/  
XTA®2 WIDE BASE**



- Advanced Technology™ compounding offers excellent fuel economy\*
- Designed to help provide even wear & cool running casing in high cube storage service
- 17.5" and 19.5" sizes
- Tread groove design helps against irregular wear and provides good wet weather performance

LH	R	O/O	U
245/70R17.5			Tread Depth
MICHELIN® XTA®2 Energy			13
Goodyear® MARATHON® LHT™			16
Bridgestone® R184			16

**XTE®**



- Long tread life from scrub resistant compound
- Extra thick casing protection from sidewall and curb guards
- Robust Michelin quality casing
- 16/32nds original tread depth

LH	R	O/O	U
11R22.5			Tread Depth
MICHELIN® XTE®			16
Goodyear® G314™			12
Bridgestone® R196			16

**XTE2®**



- Optimized for low platform and specialty trailer applications
- Solid shoulders help resist lateral scrub
- Compound for cut resistance and cool operating temperatures
- Deep channels and lateral siping enhance traction and braking in adverse weather

LH	R	O/O	U
235/75R17.5			Tread Depth
MICHELIN® XTE2®			15
Goodyear® MARATHON® LHT™ (245/70)			16
Bridgestone® R184 (245/70)			16

**XTY®2**



- Open tread design to help resist stone retention
- Cut and chip resistant compound
- Reinforced belt package for added retreadability

LH	R	O/O	U
275/70R22.5			Tread Depth
MICHELIN® XTY®2			21
Goodyear® G288 MSA®			25
Bridgestone® M840			22

\* Fuel savings are estimates based on comparative rolling resistance. Actual on-road savings may vary. Exceeding the legal speed limit is neither recommended nor endorsed.  
LH – Long Haul, R – Regional, O/O – On/Off Road, U – Urban

# MICHELIN® TRUCK TIRE REFERENCE CHART

## SPECIAL APPLICATION TIRES

**XZA®4**



- Optimized for mobile crane applications
- 50 mph\* speed rating

LH	R	O/O	U
G20 (14.00R20)			Tread Depth
MICHELIN® XZA®4			18
Goodyear®			N/A
Bridgestone®			N/A

**XZY®**



- Offset block shoulder design promotes soft soil mobility
- Application specific compound to help resist aggression from chipping and cutting
- Zig-zag groove angles help resist stone retention and drilling

LH	R	O/O	U
12.00R24			Tread Depth
MICHELIN® XZY®			23
Goodyear® G288 MSA®			25
Bridgestone® L355			26

**XZL+™/XZL™/  
XZL™ WIDE BASE**



- High traction and floatation capability
- Excellent sidewall protection
- Long, even tread wear
- Anti-chip compound
- All-wheel positions

LH	R	O/O	U
445/65R22.5			Tread Depth
MICHELIN® XZL™ WIDE BASE			27
Goodyear® G178™ S5			30
Bridgestone® L315			30

**XML™**



- All-Terrain non-directional computer enhanced tread design delivers exceptional soft soil mobility, through enhanced self-cleaning capabilities
- Offset shoulder designed for increased traction in soft soil

LH	R	O/O	U
395/85R20			Tread Depth
MICHELIN® XML™			30
Goodyear® MV/T™			26
Bridgestone®			N/A

**XDL®**



- Off-road drive tire
- Designed for excellent mileage and protection
- Chip and cut resistant compounding
- 12.00R24 size
- Restricted to 50 mph\*
- Deep 38/32nds original tread depth

LH	R	O/O	U
12.00R24			Tread Depth
MICHELIN® XDL®			38
Goodyear® G177™			40
Bridgestone® L317			39

**XS™**



- Soft soil, all-position radial for special service such as Emergency Response vehicles
- Tread design optimized to minimize sandy surface disturbance
- Efficient grip with exceptional floatation capabilities

LH	R	O/O	U
12.00R24			Tread Depth
MICHELIN® XS™			21
Goodyear®			N/A
Bridgestone®			N/A

\* Exceeding the legal speed limit is neither recommended nor endorsed.  
LH – Long Haul, R – Regional, O/O – On/Off Road, U – Urban

## PRODUCT AVAILABILITY

### URBAN

SIZE	LOAD RANGE	TREAD NAME	CATALOG NUMBER	TREAD DEPTH 32ND	WHEEL POSITION				DIRECTIONAL	RV USE	COMMENTS
					AWP	STEER	DRIVE	TRAILER			
11R22.5	H	XZU3	32873	25	■						
12R22.5	J	XZU2	43714	24	■						
275/70R22.5	J	XZU2	57317	21	■						
305/70R22.5	L	XZU2	95623	22	■						
305/85R22.5	J	XZU3	56332	26	■						
315/80R22.5	L	XZU S2	77510	23	■						
	L	XZU S	90902	23	■						
425/65R22.5	L	XZU S wb	03785	23	■						
455/55R22.5	M	X One XZU S	28513	23	■						
305/75R24.5	J	XZU3	60143	22	■						

# PRODUCT AVAILABILITY

LONG HAUL											
SIZE	LOAD RANGE	TREAD NAME	CATALOG NUMBER	TREAD DEPTH 32ND	WHEEL POSITION				DIRECTIONAL	RV USE	COMMENTS
					AWP	STEER	DRIVE	TRAILER			
10.00R15	J	XTA	70667	14				■			
215/75R17.5	J	XTA	82636	15				■			
245/70R17.5	J	XTA2 ENERGY	78370	13				■			
225/70R19.5	F	XRV	58916	13	■				■		
245/70R19.5	F	XRV	67140	14	■				■		
265/70R19.5	J	XTA2 ENERGY	83728	15				■			
445/45R19.5	M	XTA2 ENERGY (wb)	69910	18				■			
11R22.5	G	XD4	87033	30			■				
	G	XDA3	96666	26			■				
	G	XDA5	73154	30			■				
	G	XDN2	72805	27			■				
	G	XT-1	02078	12				■			
	G	XZA-1+	06032	18	■						
	G	XZA3	73162	19	■			■	■		
	H	XDN2	64321	27			■				
H	XZA3	47488	19	■			■	■			
12R22.5	H	XDN2	51753	27			■				
235/80R22.5	G	XRV	87511	16	■				■		
255/70R22.5	H	XD2	74493	25			■				
255/80R22.5	G	XRV	59634	16	■				■		
275/70R22.5	J	XZA2 ENERGY	90059	18	■				■		
275/80R22.5	G	XD4	82292	30			■				
	G	XDA ENERGY	42564	26			■				
	G	XDA3	73095	26			■				
	G	XDA5	76747	30			■				
	G	XDN2	63465	27			■				
	G	XT-1	19518	12				■			
	G	XTA ENERGY	73176	13				■			
	G	XZA-1+	18678	18	■						
	G	XZA3	73146	19	■			■	■		
	H	XZA3	69192	19	■			■	■		
H	XZA3 ANTISPLASH	08819	19	■				■			
295/60R22.5	J	XZA2 ENERGY	33215	16	■				■		
295/80R22.5	H	XZA2 ENERGY	76807	16	■				■		
J	X Coach XZ	28798	19	■							
305/70R22.5	L	XRV	93499	16	■				■		
315/80R22.5	L	XDN2 GRIP	04355	28			■	■			
	L	XZA1	47056	18	■				■		
	L	XZA2 ENERGY	76184	17	■				■		
445/50R22.5	L	X One XDA ENERGY	21881	24			■				
	L	X One XDN2	36587	27			■				
	L	X One XTA	49694	13				■			
	L	X One XTE	59070	16				■			
455/55R22.5	L	X One XDA ENERGY	57105	24			■				
	L	X One XDN2	31535	27			■				
	L	X One XTE®	30574	16				■			® Cut & chip resistant tread compound
11R24.5	G	XDA5	73177	30			■				
	G	XDN2	87459	27			■				
	G	XT-1	22754	12				■			
	G	XZA-1+	10274	18	■						
	G	XZA3	73181	19	■			■	■		
	H	XDA3	71551	26			■				
	H	XDA5	03713	30			■				
H	XDN2	87129	27			■					
275/80R24.5	G	XDA3	68934	26			■				
	G	XDA5	73166	30			■				
	G	XDN2	75684	27			■				
	G	XT-1	29684	12				■			
	G	XZA-1+	30968	18	■						
G	XZA3	73173	19	■			■	■			
305/75R24.5	J	XDA5	30987	30			■				

# PRODUCT AVAILABILITY

REGIONAL											
SIZE	LOAD RANGE	TREAD NAME	CATALOG NUMBER	TREAD DEPTH 32ND	WHEEL POSITION				DIRECTIONAL	RV USE	COMMENTS
					AWP	STEER	DRIVE	TRAILER			
10R17.5	G	XZA	05008	16	■					■	
215/75R17.5	G	XZE2	19502	16	■						
235/75R17.5	J	XTE2	01963	15				■			
8R19.5	F	XZA	60893	16	■					■	
225/70R19.5	F	XDS2	91423	18			■				
	F	XZE	81473	17	■					■	
	G	XDS2	00691	18			■				
	G	XZE	91043	17	■					■	
245/70R19.5	G	XZE	66338	18	■					■	
	H	XDS2	05797	19			■				
	H	XZE	75997	18	■					■	
265/70R19.5	G	XDE2+	95319	20			■		■		
	G	XZE2+	46194	17	■						
285/70R19.5	H	XDE2+	79456	21			■		■		
	H	XZA	13346	16	■						
	H	XZE2+	68419	18	■						
	J	XTE2	37840	18				■			
305/70R19.5	J	XZA	50505	18	■						
10.00R20	H	XZE2	01889	18	■						
9R22.5	F	XZE	75473	18	■					■	
10R22.5	F	XZE	79883	21	■					■	
	G	XDE M/S	87357	23			■				
	G	XZE	99141	21	■					■	
11R22.5	G	XDE M/S	73493	26			■				
	G	XTE	21307	16				■			
	G	XZE2	78390	22	■					■	
	H	XDE2+	37332	25			■				
	H	XDE M/S *	73927	28			■				* Cut & chip resistant tread compound
	H	XDS2	05359	26			■		■		
12R22.5	H	XDS	62208	26			■		■		
	H	XZE *	85335	22	■					■	* Cut & chip resistant tread compound
235/80R22.5	G	XZE	68749	19	■					■	
255/70R22.5	H	XZE *	61737	18	■					■	* Cut & chip resistant tread compound
255/80R22.5	G	XZE	94390	20	■					■	
275/70R22.5	J	XZE2+	78395	19	■					■	
275/80R22.5	G	XDE M/S	61426	26			■				
	G	XTE	17706	16				■			
	G	XZE2	55895	22	■					■	
	H	XZE	01637	22	■					■	
	H	XDE2+	36993	28			■				
295/60R22.5	J	X MULTIWAY XD	06376	23			■		■	■	
295/80R22.5	H	XZE2+	81993	20	■						
365/70R22.5	L	XZA	71842	19	■					■	
11R24.5	G	XDE M/S	51273	26			■				
	G	XTE	07025	16				■			
	G	XZE2	91867	22	■					■	
	H	XDE M/S *	46695	28			■				* Cut & chip resistant tread compound
	H	XDS2	06613	25			■		■		
275/80R24.5	G	XTE	33965	16				■			
	G	XZE2	75519	22	■					■	
305/75R24.5	J	XZE2	67251	22	■						

# PRODUCT AVAILABILITY

ON / OFF ROAD AND SPECIALTY TIRES											
SIZE	LOAD RANGE	TREAD NAME	CATALOG NUMBER	TREAD DEPTH 32ND	WHEEL POSITION				DIRECTIONAL	RV USE	COMMENTS
					AWP	STEER	DRIVE	TRAILER			
325/85R16	D	XML	37984	21	■						
G20 (14.00R20)	M	XZA4	70870	18	■						
14.00R20	M	XZL	59177	29	■						
16.00R20	M	XZL	06306	34	■						
395/85R20	G	XML	99131	30	■						
	J	XZL	54331	33	■						
	J	XZL+	94675	26	■						
475/80R20	J	XML	80341	30	■						
24R20.5	H	XS	23002	21	■						
24R21	H	XZL	76025	31	■						
11R22.5	G	XZY3	84455	24	■						
	H	X WORKS XDY	89725	30			■		■		Coming 3rd quarter 2011
	H	XDY-2	77416	30			■				
	H	XDY3	97079	31			■				
	H	XZY3	80927	24	■						
12R22.5	H	XZY3	47947	24	■						
275/70R22.5	J	XTY2	42407	21				■	■		
315/80R22.5	L	XDY3	40302	31			■				
	L	XZY3	40200	23	■						
385/65R22.5	J	XZY3 (wb)	53779	22	■						
	L	XFE (wb) (Steer)	36991	21		■					
425/65R22.5	L	XFE (wb) (Steer)	11829	21		■					
	L	XZL (wb)	53254	26	■						
445/65R22.5	L	XZY3 (wb)	40321	23	■						
	L	XZL (wb)	84103	27	■						
	L	XZY3 (wb)	83691	23	■						
455/55R22.5	M	XFE (wb) (Steer)	10805	21		■					
	M	X One XZY3	11629	23	■						
12.00R24	H	XZY	29163	23	■						
	J	XDL	30049	38			■				
11R24.5	G	XZY3	47945	24	■						
	H	XDY-2	76789	30			■				
	H	X WORKS XDY	90022	30			■		■		Coming 3rd quarter 2011
	H	XDY3	47962	31			■				
	H	XDY-EX2	23274	32			■				Coming 3rd quarter 2011
	H	XDY-EX	46268	32			■				
	H	XZY3	79250	24	■						
12R24.5	H	X WORKS XDY	90148	30			■		■		Coming 3rd quarter 2011
	H	XDY3	47966	31			■				
	H	XZY3	47951	24	■						

# PRODUCT SEGMENTATION

MICHELIN SEGMENTS		VOCATIONS
A	Long Haul	• Truckload Carrier
E	Regional	• Public Utilities
		• School Bus
		• Food Distribution
		• Petroleum Delivery
		• Courier and Delivery Service
		• Manufacturing
		• Auto Carriers
U	Urban	• Urban Buses • Sanitation and Refuse
Y	On/Off Road	• Construction and Mining
L	Off Road	• Forestry and Logging
		• Oil Field

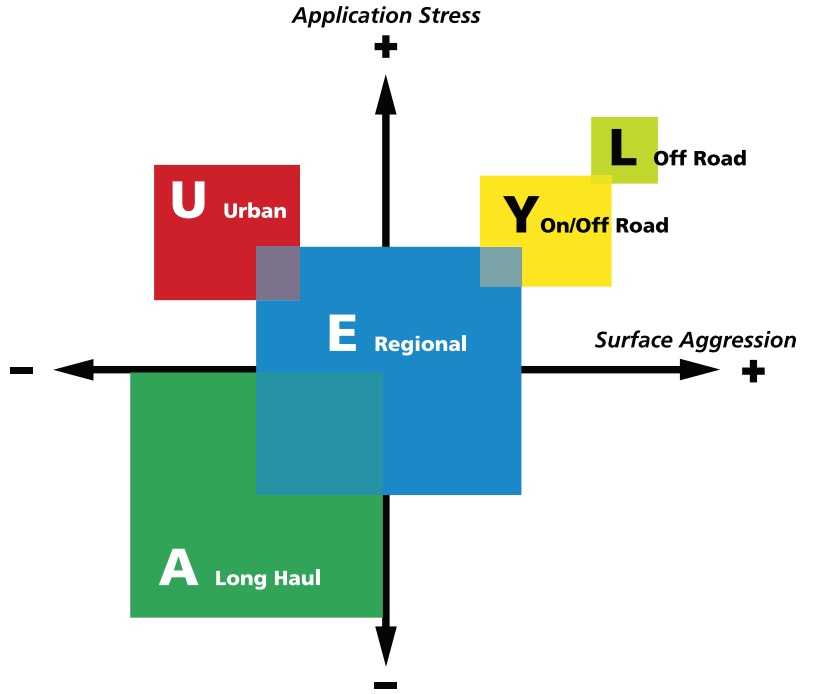

To learn more please contact your MICHELIN Sales Representative or visit [www.michelintruck.com](http://www.michelintruck.com)

To order more books, please call Promotional Fulfillment Center 1-800-677-3322, Option #2  
Monday through Friday, 9 a.m. to 5 p.m. Eastern Time

#### United States

**Michelin North America, Inc.**  
One Parkway South, Greenville, SC 29615  
**1-888-622-2306**

#### Canada

**Michelin North America (Canada), Inc.**  
2500 Daniel Johnson, Suite 500  
Laval, Quebec H7T 2P6  
**1-888-871-4444**

#### Mexico

**Industrias Michelin, S.A. de C.V.**  
Av. 5 de febrero No. 2113-A, Fracc. Industrial Benito Juarez, 7 6120, Querétaro, Qro. Mexico  
**011 52 442 296 1600**

An Equal Opportunity Employer

Copyright © 2011 Michelin North America, Inc. All rights reserved.

The Michelin Man is a registered trademark owned by Michelin North America, Inc.

MICHELIN® tires and tubes are subject to a continuous development program. Michelin North America, Inc. reserves the right to change product specifications at any time without notice or obligations.

MWL42305 (01/11)

